

# Magnolia Spring Classic

## GV Showmanship (Classes: 89, 90)

Show Date: April 17-19, 2026

w w w . H o r s e S h o w P a t t e r n s . c o m

w w w . H o r s e S h o w P a t t e r n s . c o m

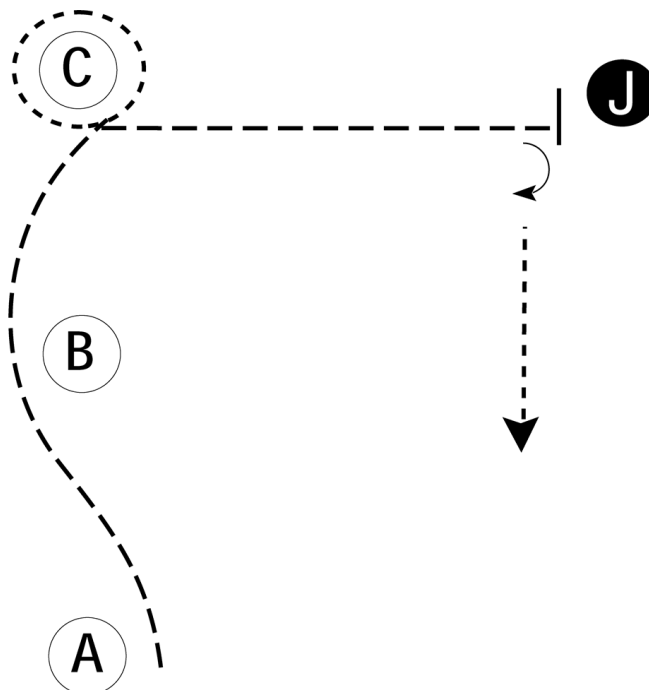

Be ready at A.

1. When acknowledged, trot from A, around B and to C.
2. Walk a tight circle around C.
3. Trot to judge.
4. Stop and set up for inspection.
5. When dismissed, perform a 90 degree turn and walk away from judge.

Follow the directions of your ring steward.

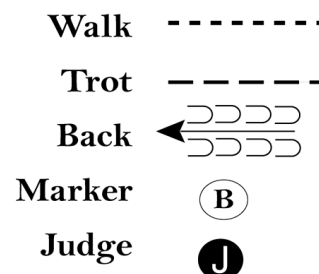

[S/1-58]

**Pattern Provided by:**  
*Lynn Daniel, Show Manager*

# Showmanship

## LEVEL 1 • PATTERN B

*Exhibitors are to complete the pattern on the side of the marker as indicated in the drawing*

- ❑ **In the Ring**— Exhibitors enter arena and remain collectively for the entire class. Exhibitors are to enter the arena at the walk. Trot at the marker and line up at the discretion of the ringmaster.
- ❑ **In and Out of the Ring**— Exhibitors enter arena one at a time and are excused at the completion of their pattern.
- ❑ **At the Gate**— Exhibitors enter arena one at a time and are gathered in arena for final inspection as a collective group.

Be ready at marker A.

Walk from marker A to marker B.

Trot from marker B to marker C.

Stop at marker C and set up for inspection.

When dismissed, back four steps.

Execute a 90-degree turn and trot to marker D as drawn. Stop.

Hesitate for several seconds and then trot to new lineup as directed by the ringmaster or exit as directed by the ringmaster.

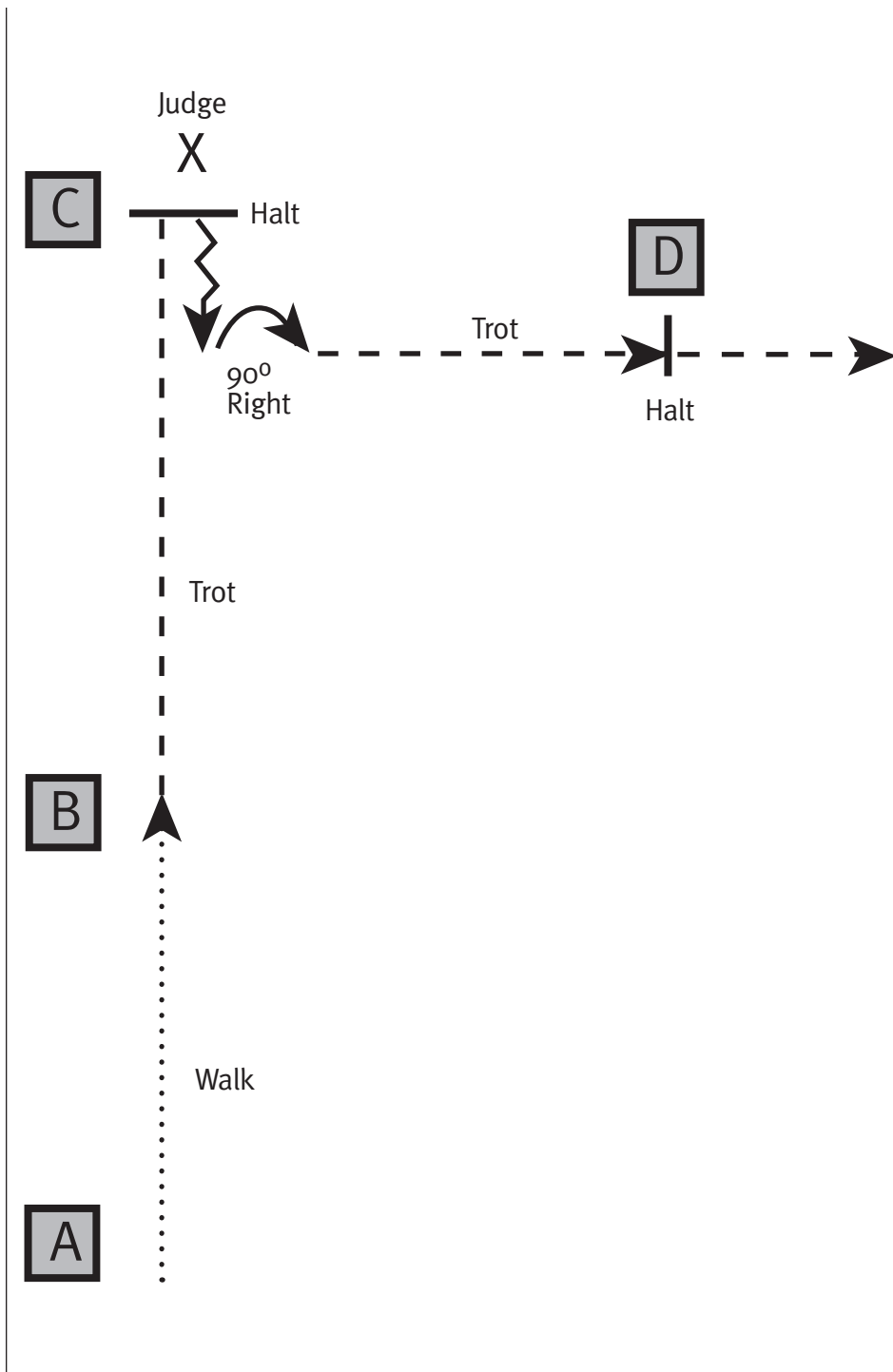

	Stop / Halt
	Canter
	Trot
	Walk
	Back
	Marker
	Lineup



# Magnolia Spring Classic

GV English Equitation - WT (Classes: 133, 134)

Show Date: April 17-19, 2026

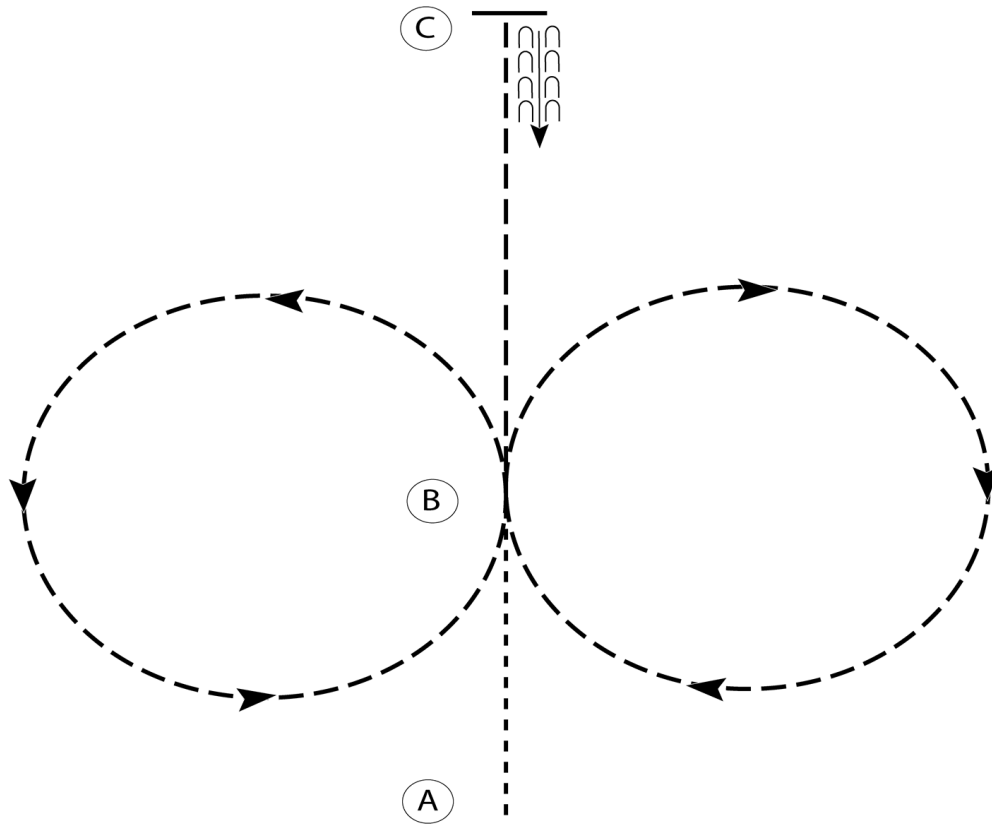

1. Walk A to B.
2. At B posting trot a circle to the right on the proper diagonal.
3. At B posting trot a circle to the left on the proper diagonal.
4. At B sitting trot to C.
5. At C stop and back approximately one horse length.

Walk	-----
Trot	- - - - -
Extended Trot	— — — — —
Canter	—————
Leg Yield	
Lead Change	— / —
Back	←←←←←
Marker	(B)
Sidepass	← — — — — →
Hand Gallop	— — — — —

[HSE/WT-5]

Pattern Provided by:

*Lynn Daniel, Show Manager*

w w w . H o r s e S h o w P a t t e r n s . c o m

w w w . H o r s e S h o w P a t t e r n s . c o m

# Magnolia Spring Classic

## GV English Equitation - WTC (Classes: 135)

Show Date: April 17-19, 2026

www.HorseShowPatterns.com

www.HorseShowPatterns.com

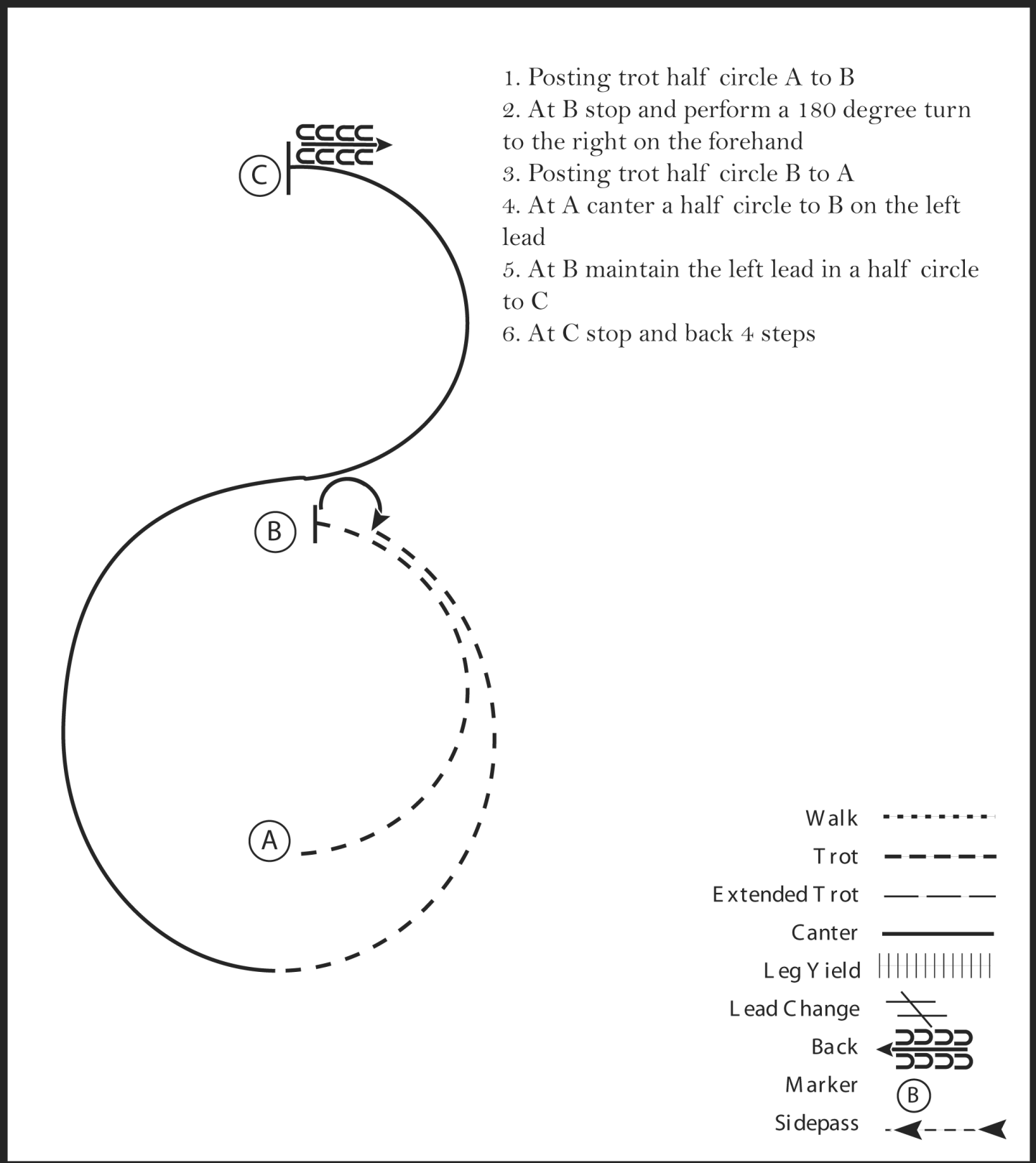

1. Posting trot half circle A to B
2. At B stop and perform a 180 degree turn to the right on the forehand
3. Posting trot half circle B to A
4. At A canter a half circle to B on the left lead
5. At B maintain the left lead in a half circle to C
6. At C stop and back 4 steps

Walk	.....
Trot	-----
Extended Trot	- - - - -
Canter	—————
Leg Yield	
Lead Change	///
Back	←←←←←
Marker	(B)
Sidepass	←- - - -←

[HSE/2-7]

Pattern Provided by:

*Lynn Daniel, Show Manager*

# Magnolia Spring Classic

GV Obstacle Driving (Classes: 162, 163)

Show Date: April 17-19, 2026

www.HorseShowPatterns.com

www.HorseShowPatterns.com

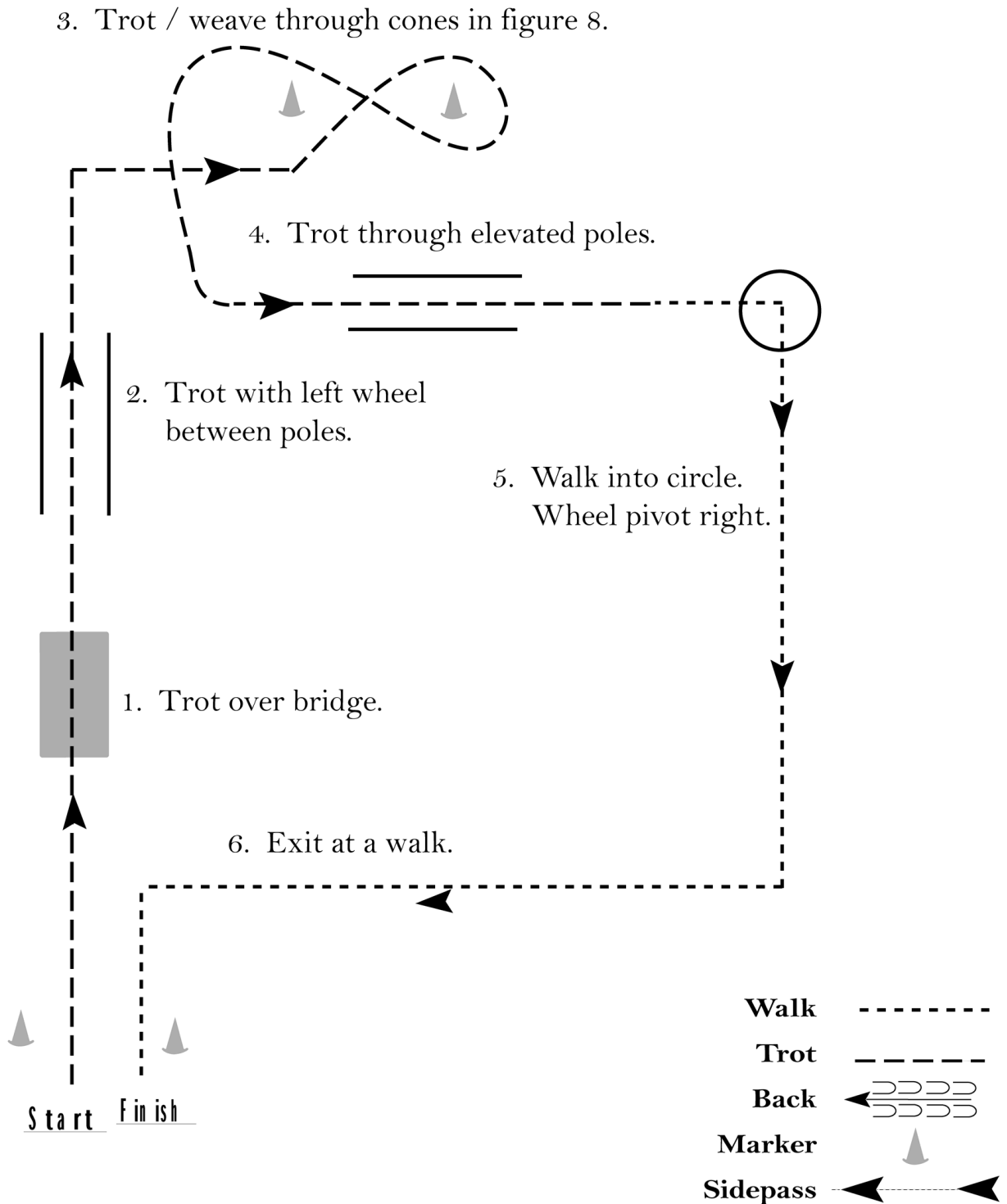

[MHP/DO-4]

Pattern Provided by:

*Lynn Daniel, Show Manager*

# Saddle Seat

## LEVEL 1 • PATTERN A • Tests 2,3,10







At the mid-point of the in-gate of the arena (A), trot to the left around the curve to the end of the straightaway on the left diagonal (B) and stop briefly.

Canter (right lead) a circle in a clockwise direction.

Go directly into the trot on correct diagonal (C) and continue to the end of the straightaway (D) and at the curve execute a circle in a clockwise direction.

Continue the trot around the curve to the mid-point of the turn (A).

Exit arena at the trot.

	Stop / Halt
	Canter
	Trot
	Walk
	Back
	Marker
	Lineup

*This pattern may only be used for:*

- 13 & Under
- 14 - 18
- 18 & Under
- 19 & Over

*If used at a Regional or National Show, pattern may not be run from the lineup.*

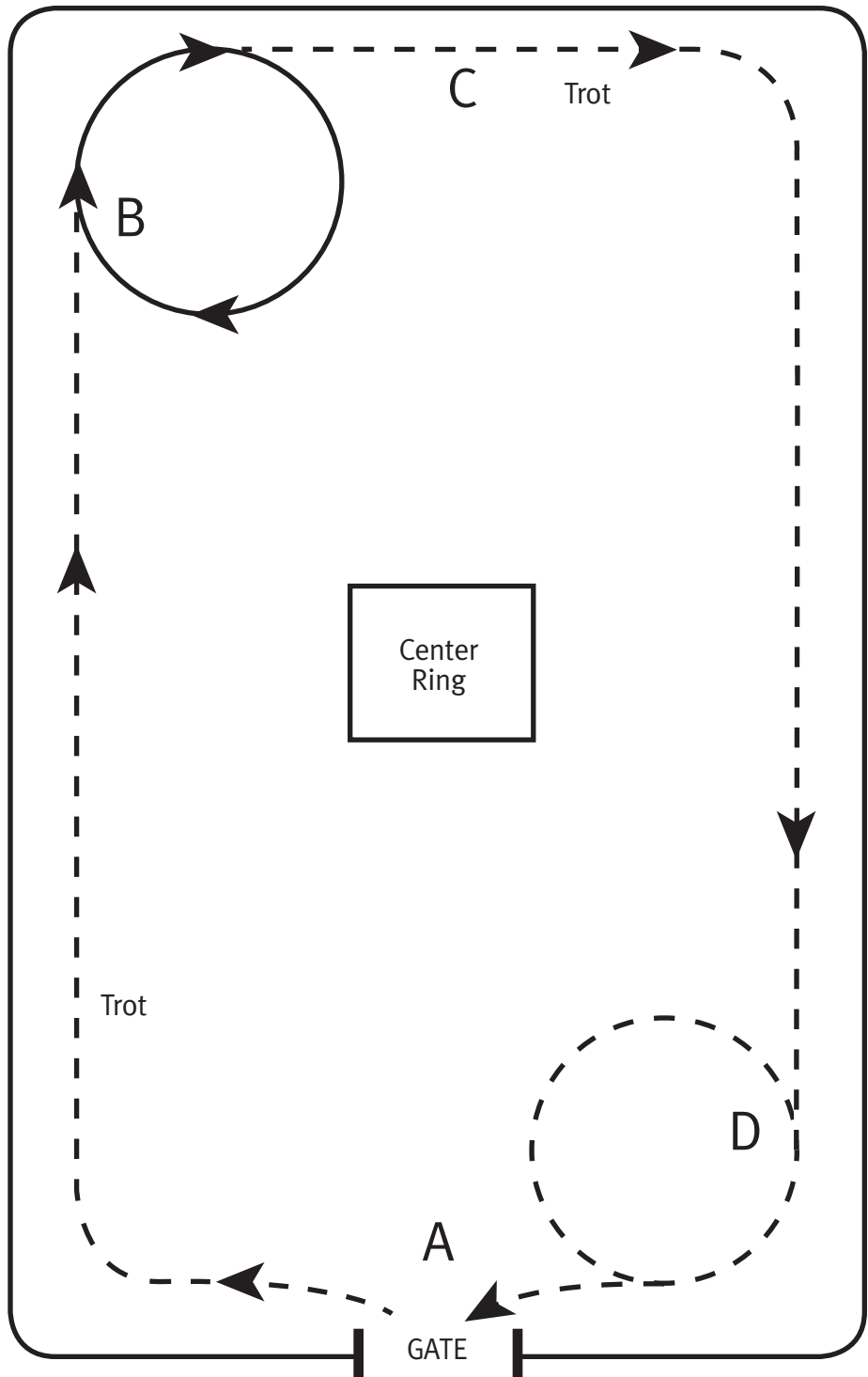

# Magnolia Spring Classic

GV Western Horsemanship - WJ (Classes: 285, 286)

Show Date: April 17-19, 2026

w w w . H o r s e S h o w P a t t e r n s . c o m

w w w . H o r s e S h o w P a t t e r n s . c o m

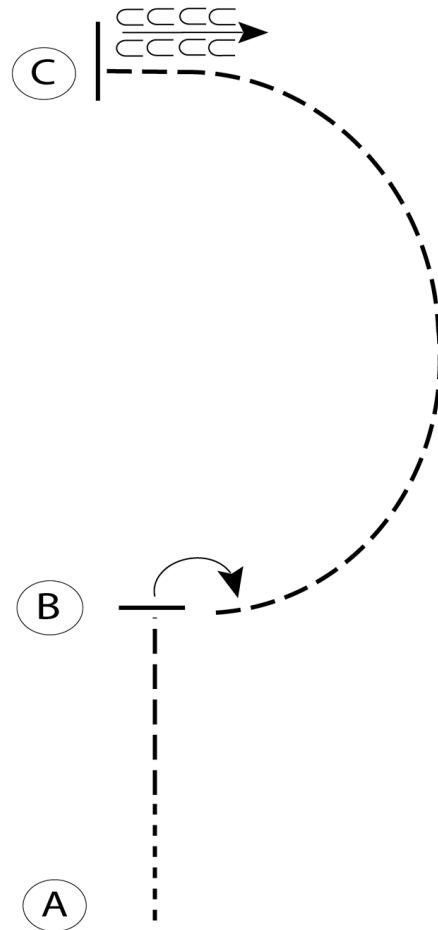

1. Be ready at A
2. Walk four steps from A.
3. Jog to B and stop.
4. Perform a 90 degree turn to the right on the hindquarters.
5. Jog a half circle to C.
6. At C stop and back four steps.

Walk	-----
Jog	- - - - -
Extended Jog	- - - - -
Lope	—————
Leg Yield	
Lead Change	— / —
Back	←←←←
Marker	⊙ B
Sidepass	←-----→

[WH/WT-16]

Pattern Provided by:

*Lynn Daniel, Show Manager*

# Magnolia Spring Classic

GV Western Horsemanship - WJL (Classes: 288)

Show Date: April 17-19, 2026

w w w . H o r s e S h o w P a t t e r n s . c o m

w w w . H o r s e S h o w P a t t e r n s . c o m

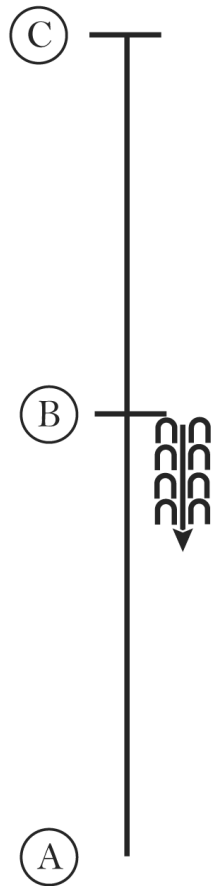

1. Lope on the right lead A to B
2. At B stop and back 4 steps
3. Lope on the left B to C
4. Stop at C and wait to be dismissed

Walk	.....
Jog	-----
Extended Jog	-----
Lope	—————
Leg Yield	
Lead Change	—/—
Back	← C C C C C C C C
Marker	(B)
Sidepass	← - - - - - →

[WH/1-11]

Pattern Provided by:

*Lynn Daniel, Show Manager*



# Magnolia Spring Classic

April 17-19, 2026

**GV WALK/TROT RANCH RIDING PATTERN #4** Classes: 290, 291, 292, 293

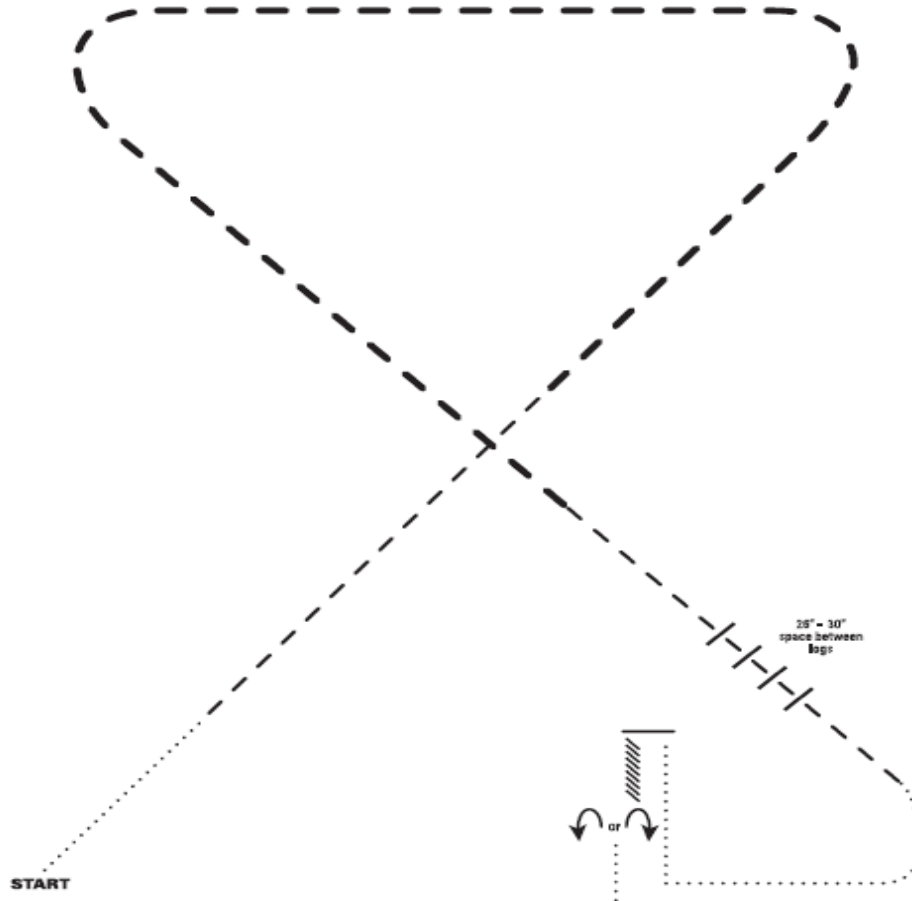

LEGEND	
.....	Walk
◆◆◆◆	Extended Walk
- - - -	Trot
— — — —	Extended Trot
————	Lope
————	Extended Lope
//////	Back
W	Lead Change

1. Walk
2. Trot
3. Extended trot
4. Trot over logs
5. Walk
6. Stop
7. Back
8. 180° (1/2) turn either direction
9. Walk

*Note: The drawn description of this pattern is only intended for the general depiction of the pattern. Exhibitors should utilize the arena space to best exhibit their horses.*

# Magnolia Spring Classic

April 17-19, 2026

**GV WALK/TROT/LOPE RANCH RIDING PATTERN #1** Classes: 296, 297, 298

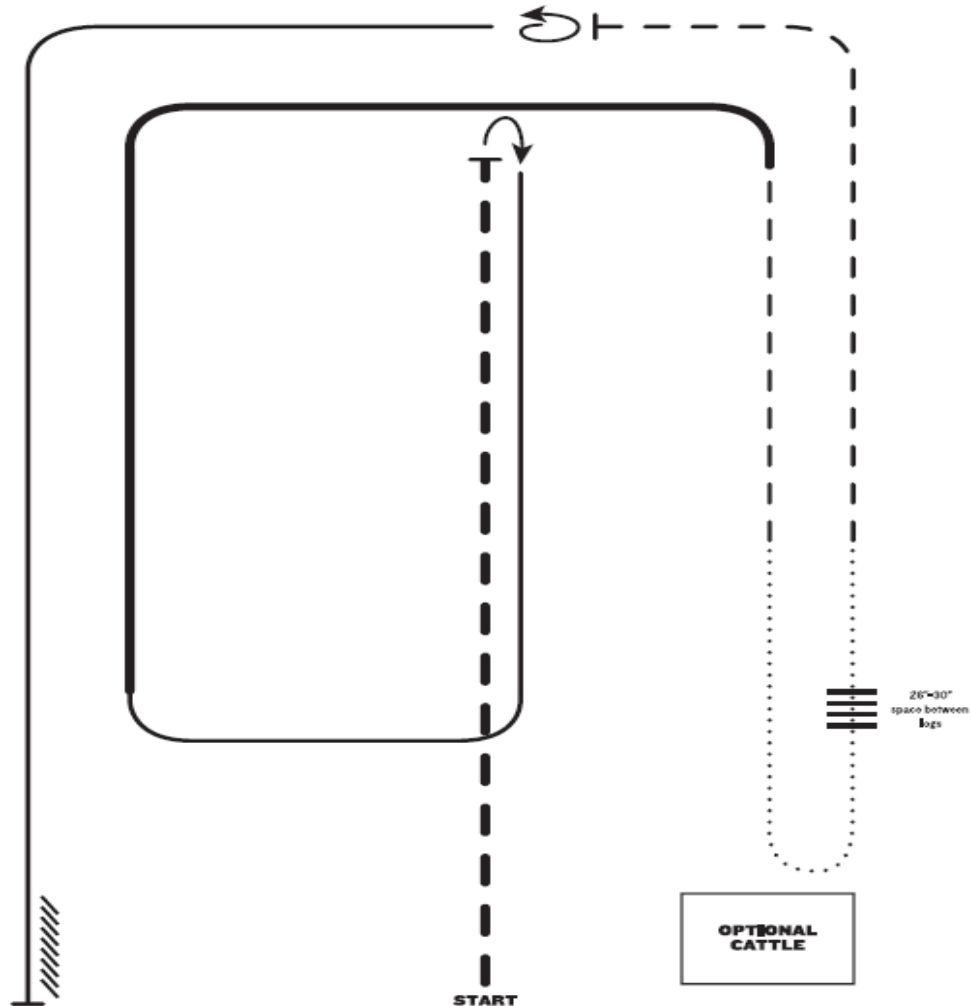

1. Extended trot
2. Stop, rollback right
3. Lope right lead
4. Extended lope right lead
5. Trot
6. Walk
7. Walk over logs
8. Walk
9. Trot
10. Stop, 360° turn left
11. Lope left lead
12. Stop and back

LEGEND	
.....	Walk
.....	Extended Walk
---	Trot
---	Extended Trot
---	Lope
---	Extended Lope
////	Back
W	Load Change

*Note: The drawn description of this pattern is only intended for the general depiction of the pattern. Exhibitors should utilize the arena space to best exhibit their horses.*





# RANCH REINING PATTERN 3 - Class 292, 293, 298, 297

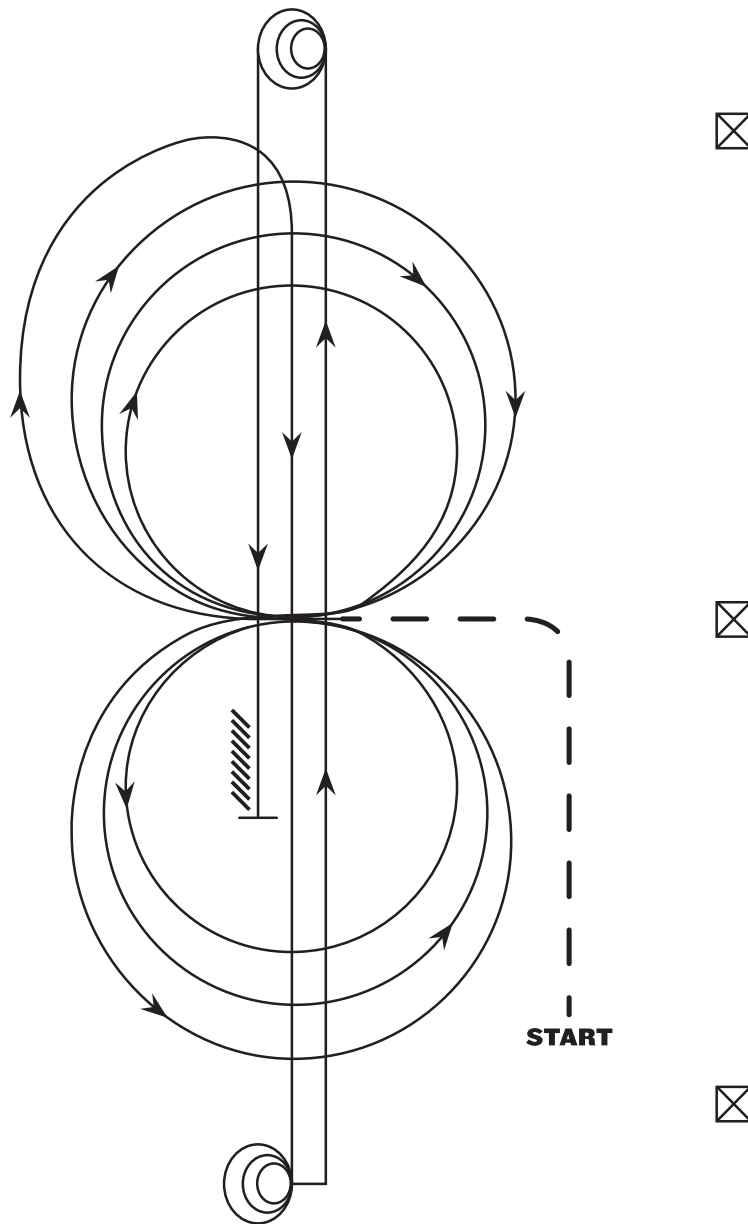

**Mandatory Marker along Fence or Wall:** The judge shall indicate with markers on arena fence or wall the center of pattern. Judge shall also place markers on fence or wall at least 50' from each end of the arena.

Ride pattern as follows: Trot to center of arena and stop or walk before departure. Start pattern facing toward judge.

1. Beginning on right lead, complete three circles to the right - the first two large and fast; the third one small and slow. Change leads at center of arena.
2. Complete three circles to the left - the first two large and fast; the third one small and slow. Change leads at center of arena.
3. Begin a large circle to the right, but do not close this circle. Run down center of arena, past the end marker, and do a sliding stop.
4. Complete 3 1/2 spins to the right.
5. Run up center of arena to the opposite end, past the end marker, do a sliding stop.
6. Complete 3 1/2 spins to the left.
7. Run back to the middle of the arena, past the center marker, and do a sliding stop. Back up at least 10 feet. Hesitate to show completion of pattern.

# REINING PATTERN I - Class #301, 302, 303, 306, 307, 308

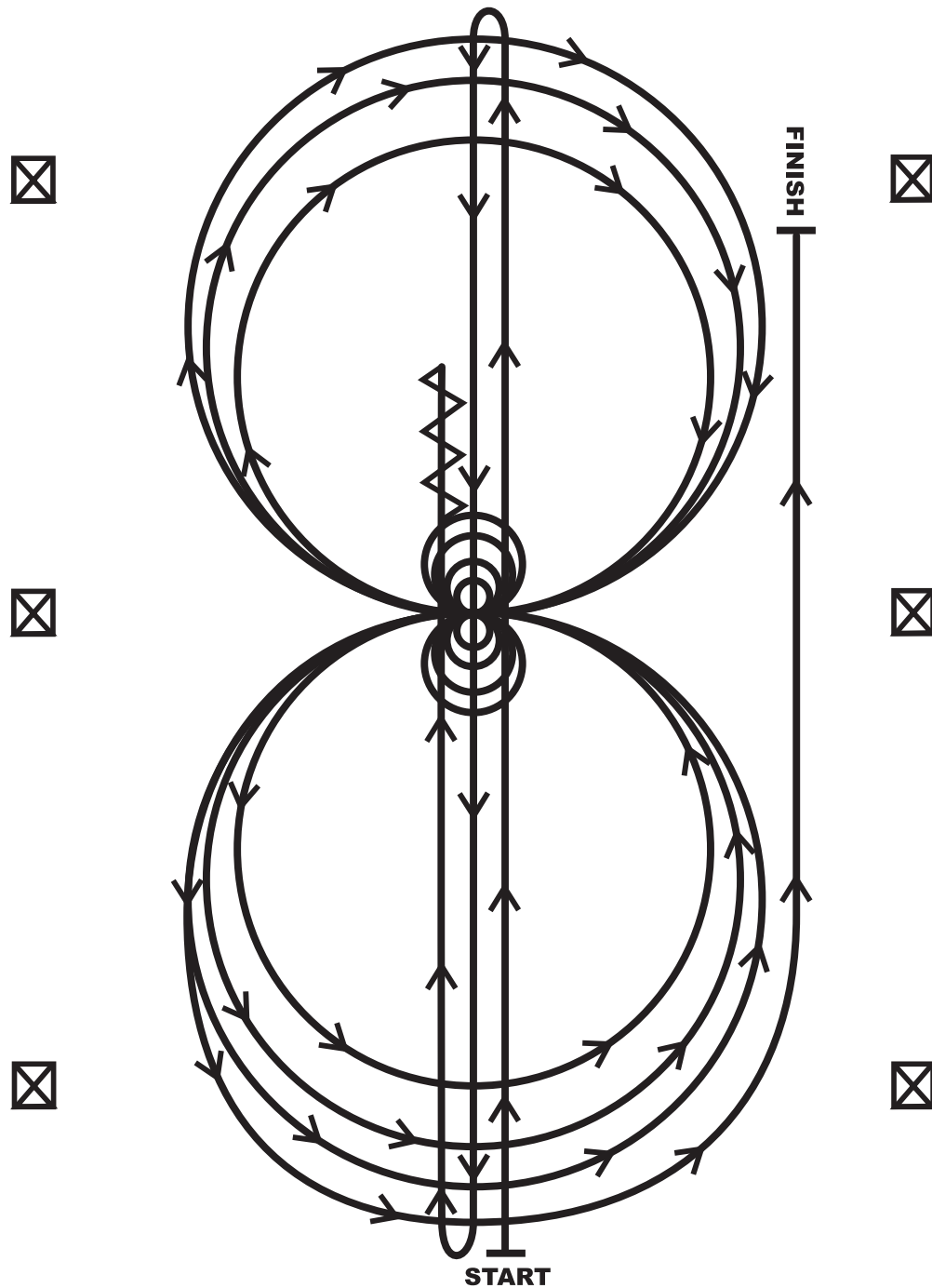

1. Run at speed to the far end of the arena past the end marker and do a left rollback—no hesitation.
2. Run to the opposite end of the arena past the end marker and do a right rollback—no hesitation.
3. Run past the center marker and do a sliding stop. Back up to center of the arena or at least ten feet (three meters). Hesitate.
4. Complete four spins to the right. Hesitate.
5. Complete four and one-quarter spins to the left so that horse is facing left wall or fence. Hesitate.
6. Beginning on the left lead, complete three circles to the left: the first circle large and fast; the second circle small and slow; the third circle large and fast. Change leads at the center of the arena.
7. Complete three circles to the right: the first circle large and fast; the second circle small and slow; the third circle large and fast. Change leads at the center of the arena.
8. Begin a large circle to the left but do not close this circle. Run straight up the right side of the arena past the center marker and do a sliding stop at least twenty feet (six meters) from wall or fence. Hesitate to demonstrate the completion of the pattern

## PATTERN 5 - Class 311 & 312 A/L & Half A/L Reining Open & ATR

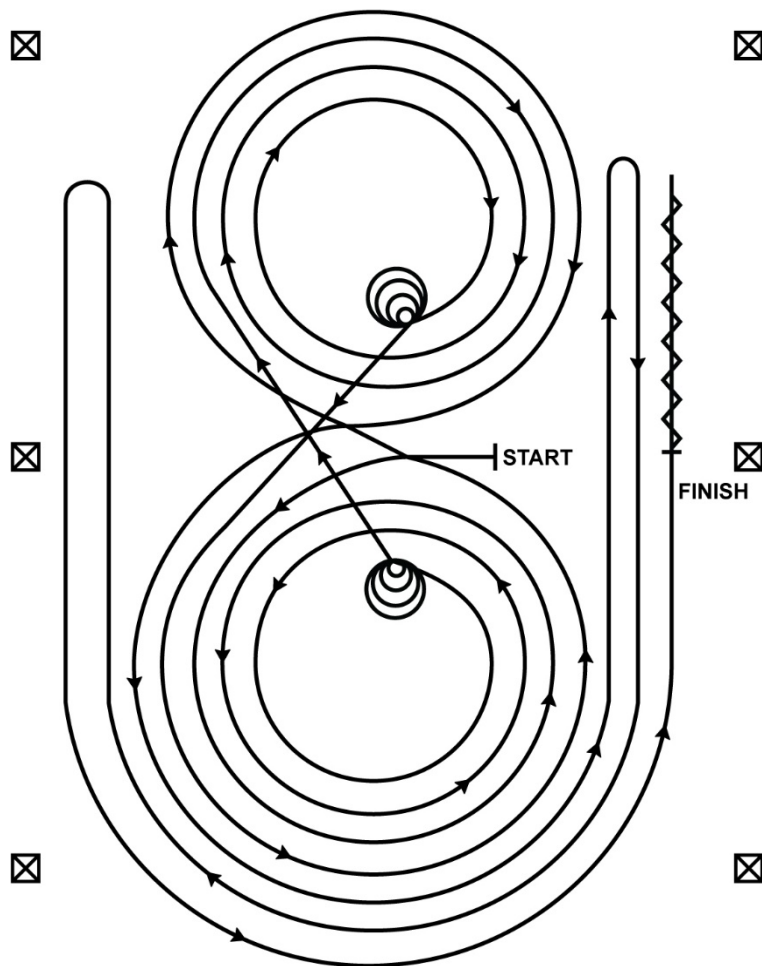

Horses may walk or trot to the center of arena. Horses must walk or stop prior to starting the pattern. Beginning at the center of the arena facing the left wall or fence.

1. Beginning on the left lead, complete three circles to the left: the first two circles large and fast; the third circle small and slow. Stop at the center of the arena. Hesitate.
2. Complete four spins to the left. Hesitate.
3. Beginning on the right lead, complete three circles to the right: the first two circles large and fast; the third circle small and slow. Stop at the center of the arena. Hesitate.
4. Complete four spins to the right. Hesitate.
5. Beginning on left lead, run a large fast circle to the left, change leads at the center of the arena, run a large fast circle to the right, and change leads at the center of the arena (figure 8).
6. Continue around previous circle to the left but do not close this circle. Run up the right side of the arena past the center marker and do a right rollback at least twenty feet (six meters) from the wall or fence—no hesitation.
7. Continue around previous circle but do not close this circle. Run up the left side of the arena past the center marker and do a left rollback at least twenty feet (six meters) from the wall or fence—no hesitation.
8. Continue back around previous circle but do not close this circle. Run up the right side of the arena past the center marker and do a sliding stop at least twenty feet (six meters) from the wall or fence. Back up at least ten feet (three meters). Hesitate to demonstrate completion of the pattern. Rider must drop bridle to the designated judge or steward as designated by the judge.

In-Hand English Trail  
In-Hand Western Trail

# 2026 Magnolia Spring Classic

AHA, IALHA, IFSHA, GVHS  
Horse Show

*Designer  
Jennifer Sawyer*

Class: # 314, 315, 316, 317, 318

Class: # 328, 329, 330, 331, 334, 335

Class: # 336, 337, 341, 342, 343, 344



Cone



Walk



Trot / Jog

X Stop

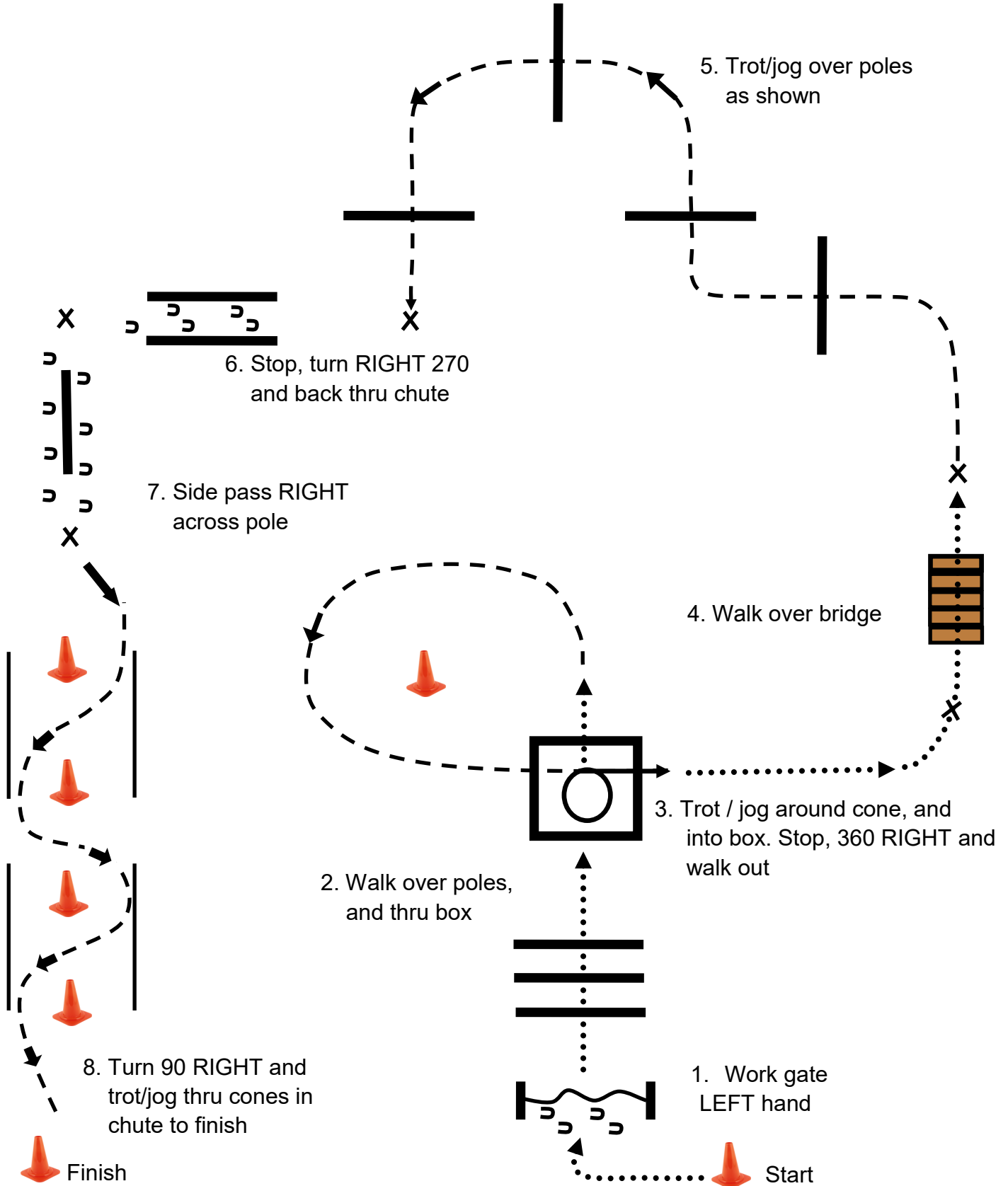

Class: # 319, 320, 321



Cone

..... Walk

- - - - Trot / Jog

X Stop

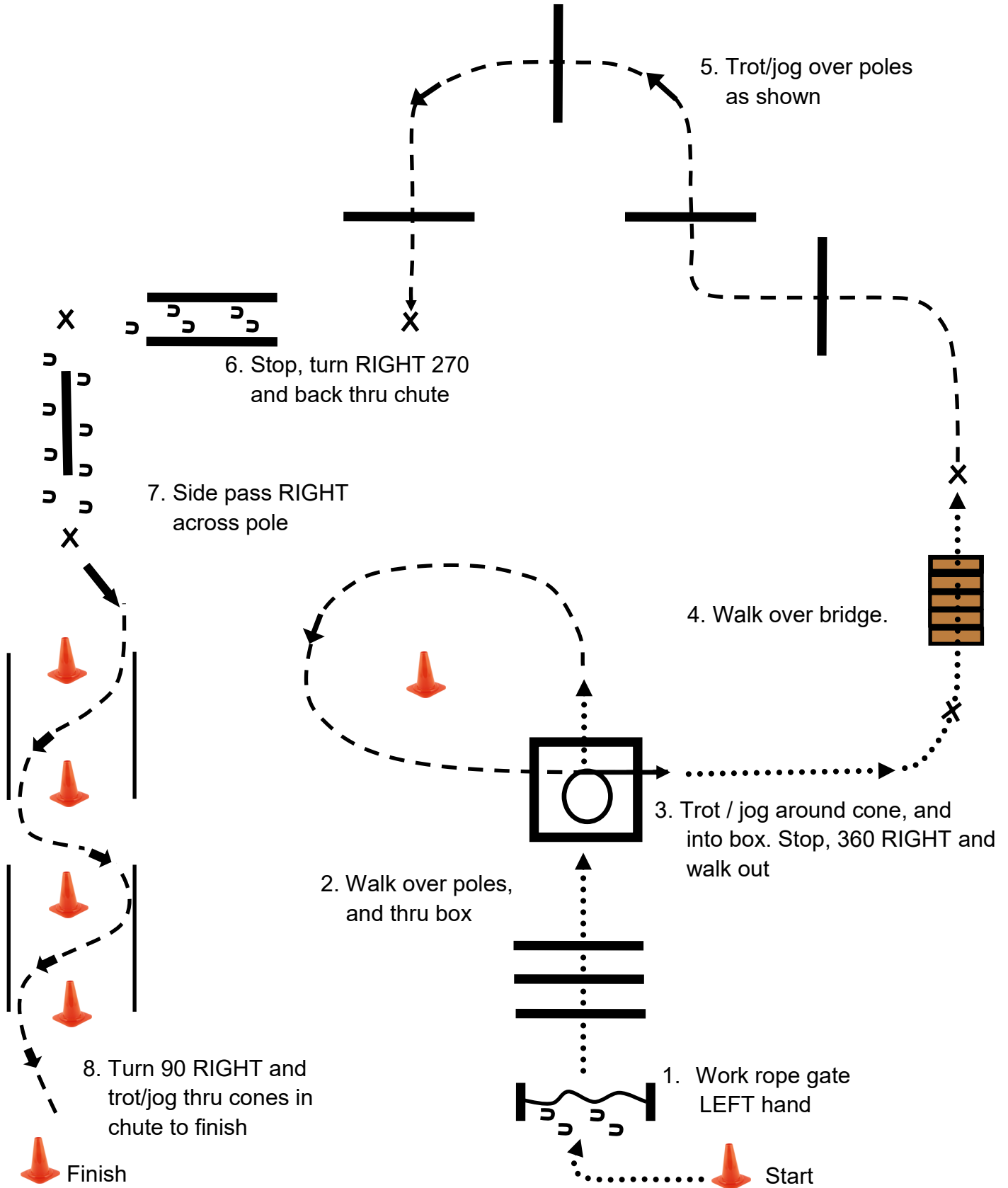

Class: # 322, 323, 324, 325

Class: # 332, 333, 338, 339

Class: # 340, 345, 346, 347,

Class: # 348, 349, 350, 351, 352

 Cone    X Stop    .....Walk    - - - - Trot / Jog    \_\_\_\_\_ Canter / Lope

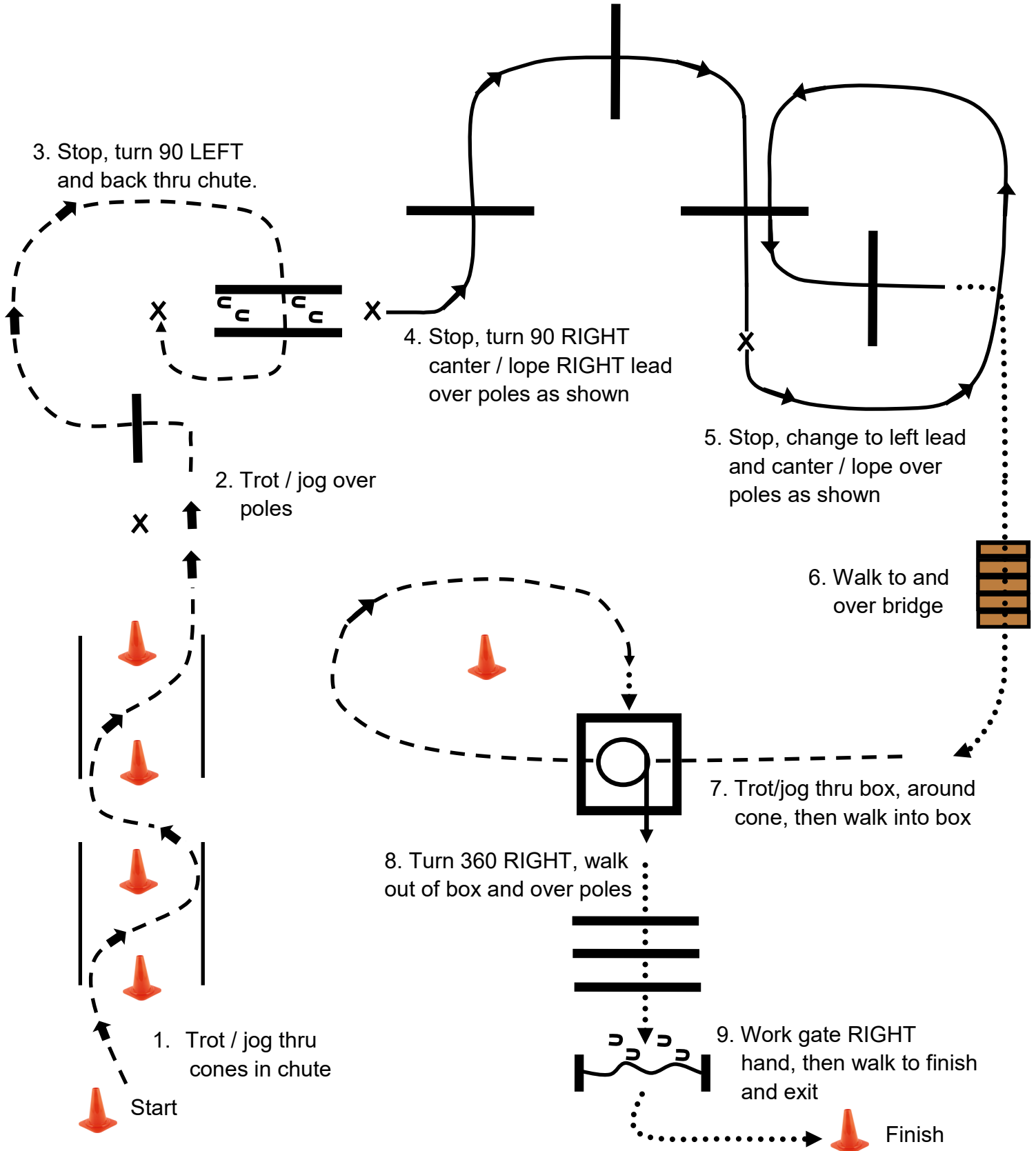

Class: # 353, 354

Class: # 355, 356

